



DUO THERMA THERMALLY INSULATED VENTILATOR

DATA SHEET

Smoke Control Duo Therma is a double flap system suited for both smoke & heat extraction and daily ventilation. This system is certified in accordance with the EN 12101-2 standard, while it is also highly air and watertight. The countless options available in terms of the base and flaps, as well as numerous operating systems and accessories, enable the creation of a functional solution for any type of building.



Area of application: from industrial properties, commercial centres, theatres and offices premises.

The cold bridge-free Duo Therma TG fitted with a thermally broken base and flaps offers a high level of durability. It minimises condensation forming and offers advanced comfort features. In the event that sound insulation is also required, two fully acoustic versions of the Duo Therma TG model are available, which have Rw values of 34 dB and 44 dB, and are fully compliant with the EN 12101-2 standard.



We believe people deserve to work & live in safe & beautiful buildings.



**SMOKE
CONTROL**



T. 1300 665 471
www.smokecontrol.com.au





TECHNICAL SPECIFICATIONS Duo Therma Ventilator

Versions

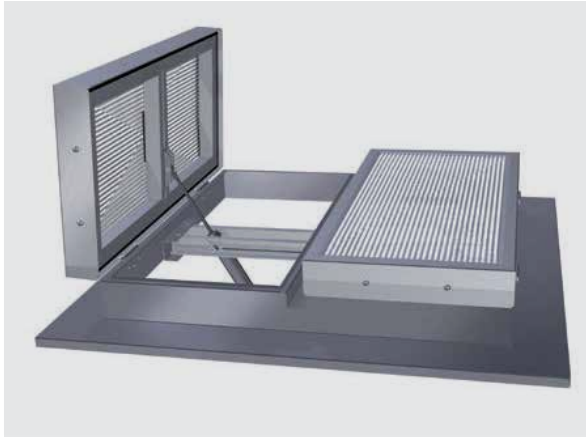

DUO THERMA AT INSULATED

- Optional transparent flaps for daylighting (see next page of product sheet)
- Broad range of operating systems and accessories available
- Suitable for all types of buildings and roof applications



DUO THERMA TG THERMALLY BROKEN

- Entirely thermally broken base and flaps
- Extensive choice of flap types
- Standard noise reduction (R_w) of 31 dB
- Increased level of comfort, with U-values of up to $0.84 \text{ W/m}^2\text{K}$
- Air and watertightness tested accordance EN 1026 / 1027 and EN 12208



DUO THERMA TG THERMALLY BROKEN / ACOUSTICALLY INSULATED

- Thermally broken base and flaps, with additional acoustic insulation
- Available in two EN 12101-2 / EN ISO 140-3 certified types, with R_w -values of 34 dB and 44 dB
- Compliant with highly stringent acoustic requirements
- U-values of 0.53 up to $0.66 \text{ W/m}^2\text{K}$



We believe people deserve to work & live in safe & beautiful buildings.

1300 665 471 | info@smokecontrol.com.au | www.smokecontrol.com.au





TECHNICAL SPECIFICATIONS Duo Therma Ventilator

Type	Throat size width x length (mm)	Geometric surface m ²	Aerodynamic surface m ²	C _v -value	Height mm (TG Acoustic = 250mm)	Duo Therma AT (un)insulated		Duo Therma TG Thermally broken							
						Weight (kg)									
						Uninsulated aluminium	Insulated aluminium	Transparent multi-wall polycarbonate Isolux	Single laminated safety glass	Insulated aluminium	Transparent multi-wall polycarbonate Isolux	Laminated insulation glass	Acoustic insulated		
1010	1000 x 1000	1.00	0.60	0.60	200	31	41	32	63	44	43	72	88		
1015	1000 x 1500	1.50	0.90	0.60	200	38	49	39	80	53	51	93	120		
1020	1000 x 2000	2.00	1.20	0.60	200	45	57	46	98	62	59	115	153		
1025	1000 x 2500	2.50	1.50	0.60	200	52	65	53	116	72	68	137	185		
1510	1500 x 1000	1.50	0.90	0.60	200	37	48	37	81	53	51	94	119		
1515	1500 x 1500	2.25	1.35	0.60	200	44	57	45	103	64	60	122	163		
1520	1500 x 2000	3.00	1.80	0.60	200	52	67	53	126	75	69	150	206		
1525	1500 x 2500	3.75	2.25	0.60	200	60	76	61	148	86	78	179	250		
2010	2000 x 1000	2.00	1.30	0.65	200	42	55	43	98	63	59	115	151		
2015	2000 x 1500	3.00	1.95	0.65	200	51	66	51	126	75	69	151	205		
2020	2000 x 2000	4.00	2.60	0.65	200	60	77	60	153	88	79	186	260		
2025	2000 x 2500	5.00	3.25	0.65	200	69	88	68	181	100	88	221	315		
2510	2500 x 1000	2.50	1.63	0.65	200	48	61	48	116	73	67	137	182		
2515	2500 x 1500	3.75	2.44	0.65	200	58	74	57	149	87	78	179	248		
2520	2500 x 2000	5.00	3.25	0.65	200	68	86	66	181	100	88	222	314		
2525	2500 x 2500	6.25	4.06	0.65	200	78	99	75	214	114	99	264	379		

The C_v-value of the Duo Therma is tested in combination with wind baffles. Deviations can be made depending on the situation in which it is installed.

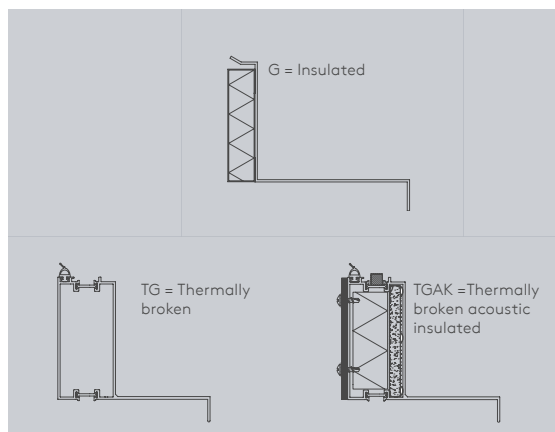

Base

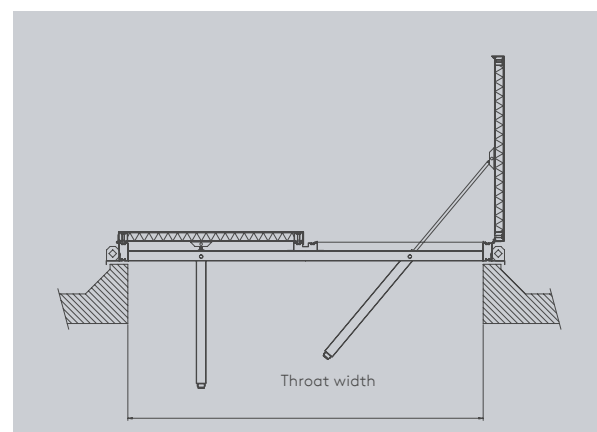

Cross Section



We believe people deserve to work & live in safe & beautiful buildings.

1300 665 471 | info@smokecontrol.com.au | www.smokecontrol.com.au





TECHNICAL SPECIFICATIONS Duo Therma Ventilator

MATERIAL

Base and flanges: Sea water and corrosion-resistant EN AW 5754 (AlMg3) sheet aluminium is used in Duo Therma AT models; Duo Therma TG models are made of EN AW 6060 (AlMgSi0,5) extruded, thermally broken profile sections.

Sealing: All-round, using coated EPDM rubbers, which prevent freezing while providing a high level of airtightness.

Hinges: Stainless steel.

Flaps: With or without thermal separator. Choice of: uninsulated or mineral wool-insulated aluminium flap, 16 mm transparent multi-wall polycarbonate filler, single safety glass, insulated safety glass, or a high quality acoustically insulated flap.

Finishing: Standard mill finished or coated in a standard RAL colour.

CONTROLS

Natural ventilation:

P2 double-action compressed air operation
M motor operation

Fire ventilation according to EN 12101-2:

P2B double-acting compressed air operation with fire function
PB-FS single-acting compressed air operation with fire function fail safe
M motor operation

ACCESSORIES

- Bird or insect mesh
- Insulated flanges
- Fall protection
- RAL colour / Anodised
- Burglary prevention features

Smoke Control Duo Therma TG has been acoustically tested in various panel compositions with and without additional acoustic damping in base*).

Sound Reduction Index (Rw) and Sound Transmission Class (STC):

Panel type	Rw, (C), (Ctr) in dB from - to	STC from - to	Panel weight (kg/m ²) from - to
Sandwich panel	31 (-2), (-6) - 44 (-1), (-3)	31 - 44	9,15 - 42,66
Insulation glass	32 (0), (-2) - 37 (-1), (-4)	32 - 37	35,00 - 35,00

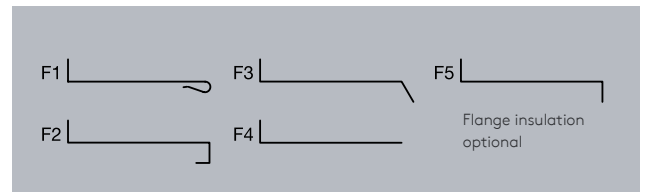

Flanges

AT-flaps		U-value W/m ² K
	Single laminated glass	5.6
	Insulated 50mm	0.64
	Insulated 100mm	0.34
	Isolux 16 mm	1.8 - 2.3

TG-flaps		U-value W/m ² K
	Thermally broken Insulated 50mm	0.64
	Thermally broken Insulated 100mm	0.34
	Thermally broken Isolux 16 mm	1.8 - 2.3
	Thermally broken laminated insulation glass	1.1 - 2.8
	Thermally broken acoustic insulated	0.37

Flaps

*) Inquire about detailed composition and intermediate values



We believe people deserve to work & live in safe & beautiful buildings.

1300 665 471 | info@smokecontrol.com.au | www.smokecontrol.com.au

